



LEAD TAPING 帶式貼品

配合自動插入機之作業,凡電容器尺寸在 130x25mm 以下者可貼品。

Taping capacitors for automatic insertion are available for their size up to 13×25.

Diagram of Dimensions

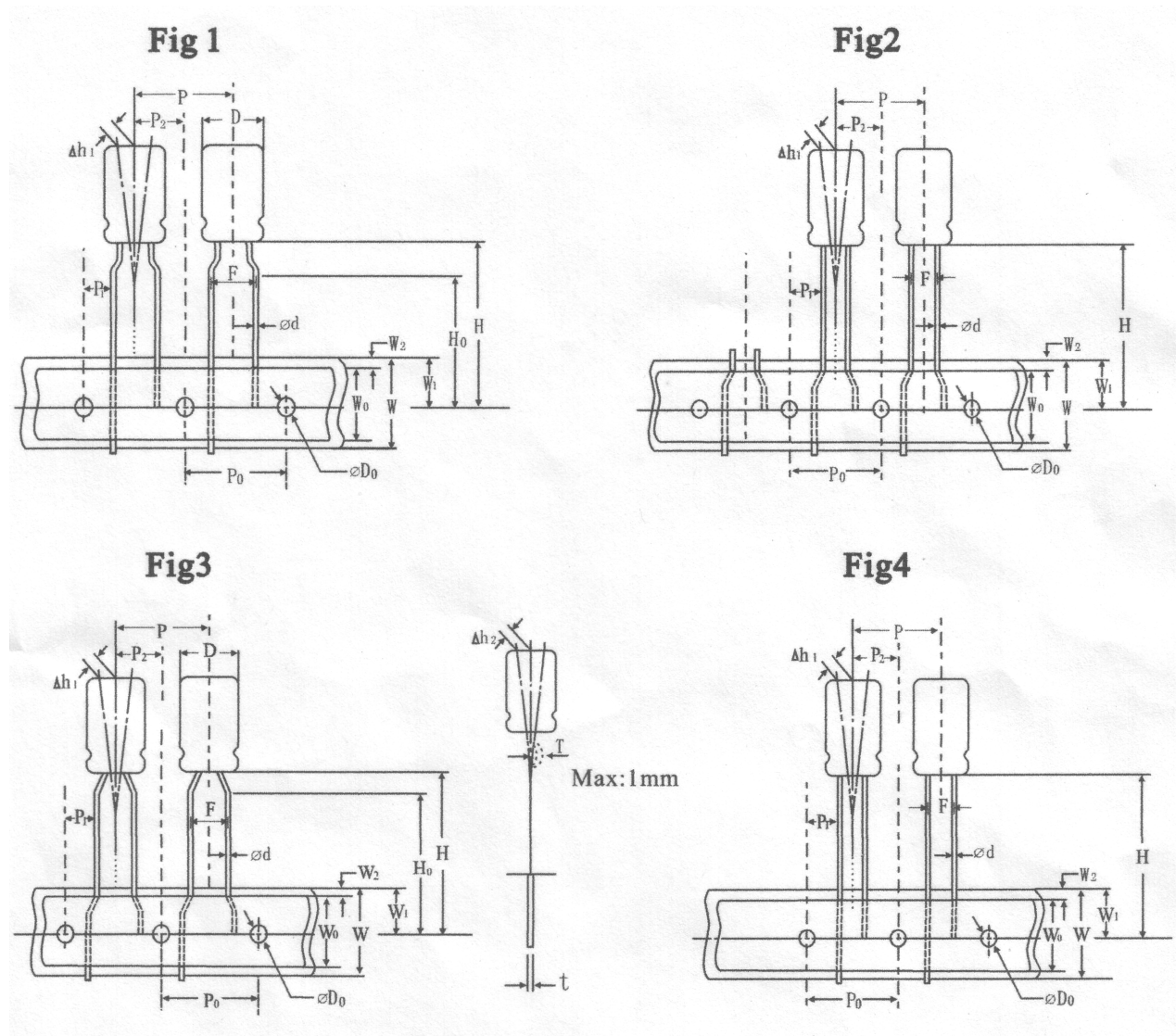

PACKAGE DIMENSION

UNIT: mm

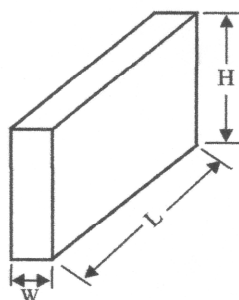

SYMBOL	30	40	50	6.30	80	100	130
L	335	335	335	335	335	330	340
W	45	45	45	45	45	50	65
H	230	230	230	230	230	300	320



SPECIFICATION DIMENSIONS 規格尺寸錶(unit:mm)

Item Symbol	Case Size	Ø3×5	Ø 4×5	Ø 5×5	Ø 6.3×5	Ø 8×5	Tolerance	Remark
Fig Dimension figure 形狀尺寸圖		1,2,3			1,2			
ØD Lead wire diameter 導線直徑		0.4	0.45			0.45	0.1	
P Pitch of body 本體間距		12.7					1.0	
P₀ Feed hole pitch 沖孔距離		12.7					0.3	
P₁ Hole center to lead 沖孔與導線距離		5.10(3)	5.60(2) 5.10(3) 3.85(1)	5.35(2) 5.10(3) 3.85(1)	5.10(2) 3.85(1)	5.10(2) 3.85(1)	0.7	
P₂ Feed hole center to component center 沖孔與本體導線距離		6.35					1.0	
F Lead spacr(center of lead) 導線距離		2.5(3)	1.5(2) 2.5(3) 5.0(1)	2.0(2) 2.5(3) 5.0(1)	2.5(2) 5.0(1)	3.5(2) 5.0(1)	+0.6 -0.4	
W Tape width 台紙寬度		18.0					0.5	
W₀ Holddown tape width 粘貼紙寬度		10.0					MIN	
W₁ Deviation between holes and base tape 沖孔與台紙偏差		9.0					0.6	
H Deviation between body bottom and tape center 本體下端與台紙中心距離		18.5					0.8	
H₀ Lead-wire clinch height 導線成型高度		16.0					0.5	
ØD₀ Feed hole diameter 沖孔孔徑		4.0					0.3	
T Base and a adhesive tape thickness 台紙與粘貼紙厚度		0.7					0.2	
Δh₁ Deviation of body alignmet 本體上下偏差		1.0					MAX	
Δh₂ Deviation of body alignment 本體左右偏差		2.0					MAX	
Quantity(Pcs/Box)包裝數量(個)		3000	3000	2000	1500	1000		



SPECIFICATION DIMENSIONS 規格尺寸錶(unit:mm)

Item Symbol	Case Size	Size				Tolerance	Remark
		Ø4×7	Ø5×7	Ø6.3×7	Ø8×7		
Fig Dimension figure 形狀尺寸圖		1,2,3		1,2			
ØD Lead wire diameter 導線直徑		0.45			0.5	0.1	
P Pitch of body 本體間距		12.7				1.0	
P₀ Feed hole pitch 沖孔距離		12.7				0.3	
P₁ Hole center to lead 沖孔與導線距離		5.60(2) 5.10(3) 3.85(1)	5.35(2) 5.10(3) 3.85(1)	5.10(2) 3.85(1)	4.60(2) 3.85(1)	0.7	
P₂ Feed hole center to component center 沖孔與本體導線距離		6.35				1.0	
F Lead spacr(center of lead) 導線距離		1.5(2) 2.5(3) 5.0(1)	2.0(2) 2.5(3) 5.0(1)	2.5(2) 5.0(1)	3.5(2) 5.0(1)	+0.6 -0.4	
W Tape width 台紙寬度		18.0				0.5	
W₀ Holddown tape width 粘貼紙寬度		10.0				MIN	
W₁ Deviation between holes and base tape 沖孔與台紙偏差		9.0				0.6	
H Deviation between body bottom and tape center 本體下端與台紙中心距離		18.5				0.8	
H₀ Lead-wire clinch height 導線成型高度		16.0				0.5	
ØD₀ Feed hole diameter 沖孔孔徑		4.0				0.3	
T Base and a adhesive tape thickness 台 紙與粘貼紙厚度		0.7				0.2	
Δh₁ Deviation of body alignmet 本體上下偏差		1.0				MAX	
Δh₂ Deviation of body alignment 本體左右偏差		2.0				MAX	
Quantity(Pcs/Box)包裝數量(個)		3000	2000	1500	1000		



SPECIFICATION DIMENSIONS 規格尺寸錶(unit:mm)

Item Symbol	Case Size		Ø 8×11.5 Ø 8×14	Ø 8×16 Ø 8×20	Ø 10×12 Ø 10×16 Ø 10×20	Ø 13×20 Ø 13×25	Tolerance	Remark
	Ø5×11	Ø 6.3×11						
Fig Dimension figure 形狀尺寸圖	1,2,3	1,2,			4			
ØD Lead wire diameter 導線直徑	0.5		0.5,0,6		0.6		0.1	
P Pitch of body 本體間距	12.7				15		1.0	
P₀ Feed hole pitch 沖孔距離	12.7				15		0.3	
P₁ Hole center to lead 沖孔與導線距離	5.35(2) 5.10(3) 3.85(1)	5.10(2) 3.85(1)	4.60(2) 3.85(1)		3.85(4)	5(4)	0.7	
P₂ Feed hole center to component center 沖孔與本體導線距離	6.35				7.5		1.0	
F Lead spacr(center of lead) 導線距離	2.0(2) 2.5(3) 5.0(1)	2.5(2) 5.0(1)	3.5(2) 5.0(1)		5.0(4)	5.0(4)	+0.6 -0.4	
W Tape width 台紙寬度	18.0						0.5	
W₀ Holddown tape width 粘貼紙寬度	10.0						MIN	
W₁ Deviation between holes and base tape 沖孔與台紙偏差	9.0						0.6	
H Deviation between body bottom and tape center 本體下端與台紙中心距離	18.5			19.0		0.8		
H₀ Lead-wire clinch height 導線成型高度	16.0					0.5		
ØD₀ Feed hole diameter 沖孔孔徑	4.0						0.3	
T Base and a adhesive tape thickness 台紙與粘貼紙厚度	0.7						0.2	
Δh₁ Deviation of body alignmet 本體上下偏差	1.0						MAX	
Δh₂ Deviation of body alignment 本體左右偏差	2.0						MAX	
Quantity(Pcs/Box)包裝數量(個)	2000	1500	1000	1000	800	500		